

# Albany 40 Series Pumps

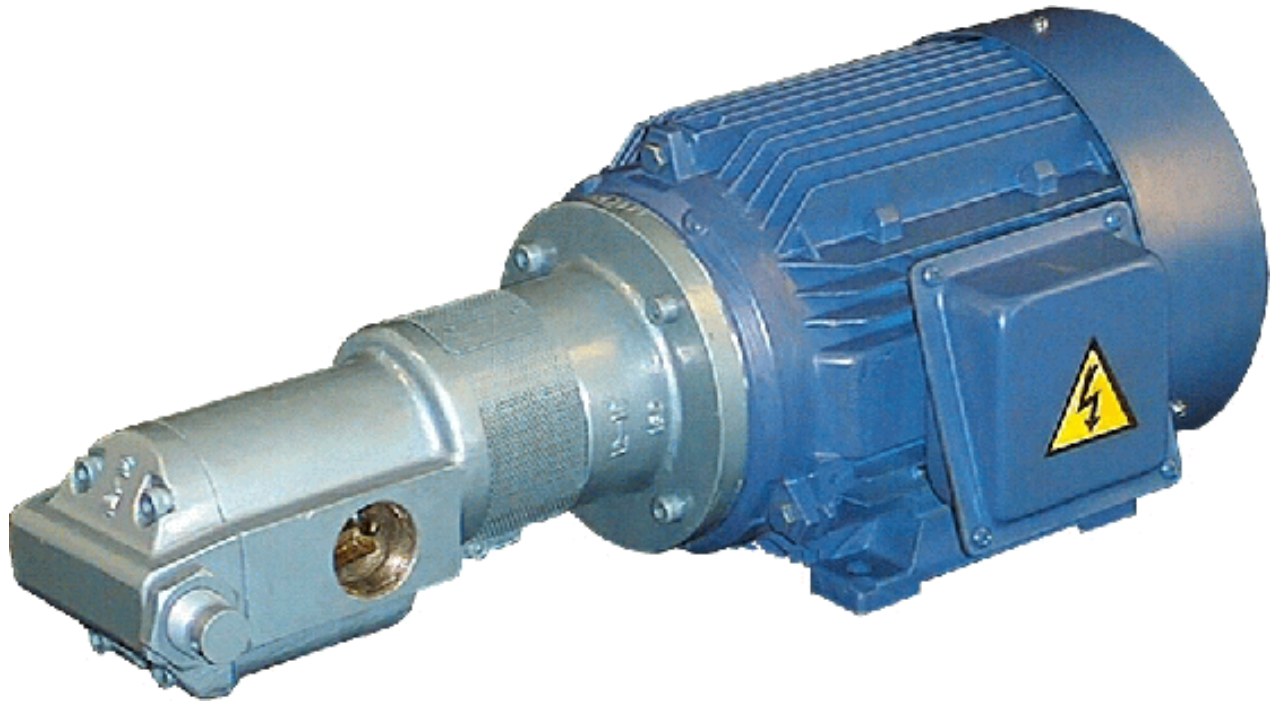

## Albany Standard Pumps

(a Division of The Albany Engineering Company Limited)

Richter Works  
Garnett Street  
Bradford  
BD3 9HB

Tel No: +44 (0) 1274 725 351  
Fax No: +44 (0) 1274 742 467  
e-mail: [asp@albany-pumps.co.uk](mailto:asp@albany-pumps.co.uk)  
[Http://www.albany-pumps.co.uk](http://www.albany-pumps.co.uk)

Head Office:  
Albany Engineering Co. Limited  
Church Road,  
Lydney,  
GLOS. GL15 5EQ

Tel No: +44 (0) 1594 842275  
Fax No: +44 (0) 1594 842574

# 40 Series Models

Compact and robust gear pumps with cast iron casings, steel rotors and shafts. Adjustable internal relief valves are available on all pumps

## FEATURES

- Self-priming
- Constant, non-pulsating flow
- Rotational speeds between 100 rev/min and 1725 rev/min
- Packed adjustable gland, lip seal or mechanical seal
- Choice of bearings
- Motor drive or bare drive shaft
- Electric or air motor drive for normal, extreme or hazardous conditions
- Individually tested

## PRESSURE, FLOW & SUCTION

40 Series gear pumps can produce pressures up to 10 bar depending on available power supply (kW) and liquid. Powers listed in performance tables cover relief valve pattern pumps with discharge pressures up to that stated.

The rate of flow is proportional to the running speed.

Suction lift will vary according to the shaft speed, viscosity and the vapour pressure.

## TEMPERATURE

Running at recommended speeds standard pumps can handle liquids at temperatures from 0°C – 85°C.

Special pumps are available for liquids at extreme temperatures.

## ROTORS

40 Series pumps are fitted with spur gear rotors.

**MOUNTING** – for options and type references see dimension drawings.

## ROTATION

Standard rotation is clockwise, looking from the drive shaft end of the pump. This direction of rotation will be supplied unless otherwise requested.

## APPLICATIONS

Machine tools, sprayers, packaging machinery, bottle washing, de-icing, damp proofing, timber treatment, oil and solvent re-cycling, fuel oil systems, pressure testing, processing, de-greasing, general circulation, lubrication and transfer duties.

## LIQUIDS HANDLED

Fuel oils, coolants, lubricants, solvents, bitumen, liquid wax, molasses, cooking oil, glue, varnish, detergents, anti-freeze, insecticides, sodium hydroxide, paints etc.

## VISCOSITY

40 Series gear pumps are individually tested on oil. The performance details shown are based on these tests at the viscosities stated. Viscosity will rise as temperature falls. Viscous liquids will cavitate at high running speeds. Cavitation can be prevented by heating liquids to reduce viscosity, or pumping at low speeds or both.

## RELIEF VALVES

Relief valves are pre-set to protect the motor from overload. They are not suitable for use as control valves. The relief valve can be supplied for external relief if needed.

## SEALING

Lip seals are standard on all type F models. Packed glands are standard on all type P models with mechanical seal as an option.

Nitrile mechanical seals are standard on type O models. Viton mechanical seals are an option.

## SUCTION CONDITIONS

Pumps are suitable for suction lifts up to 3m. However, it is advisable for lifts over 2m, long suction runs & suction losses over 0.4 bar to contact Albany sales for advice.

**NOTE:** Suction head and static discharge head on lip seal models must not exceed 0.34 bar g

# Dimensions

MODEL TYPE 'P' 40 pedestal mounting, available with: PACKED GLAND or MECHANICAL SEAL

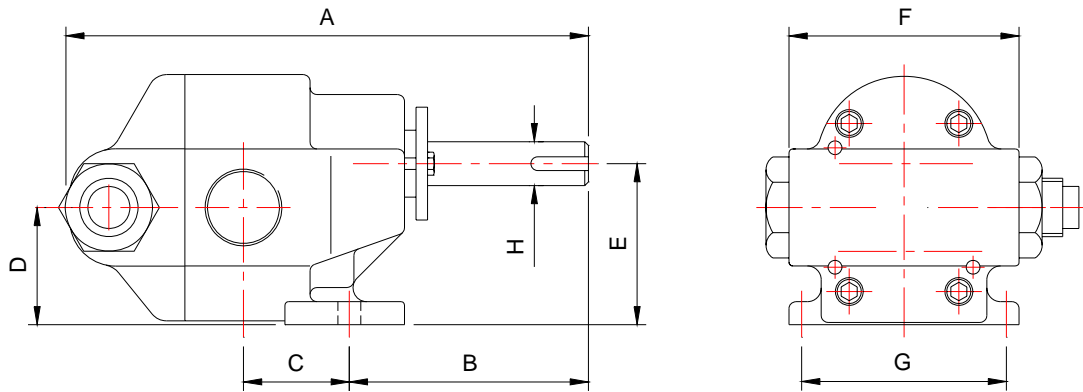

Model 'P'	mm								Branch BSP female	WEIGHT kg
	A	B	C	D	E	F	G	H		
40-1300	214	102	34	51	70	100	76	19	1"	6.4
40-1750	225	101	34	51	70	100	76	19	1"	7.2
40-2750	251	101	38	51	70	100	76	19	1.1/4"	8.9

MODEL TYPE 'F' 40 flange mounting with: LIP SEAL

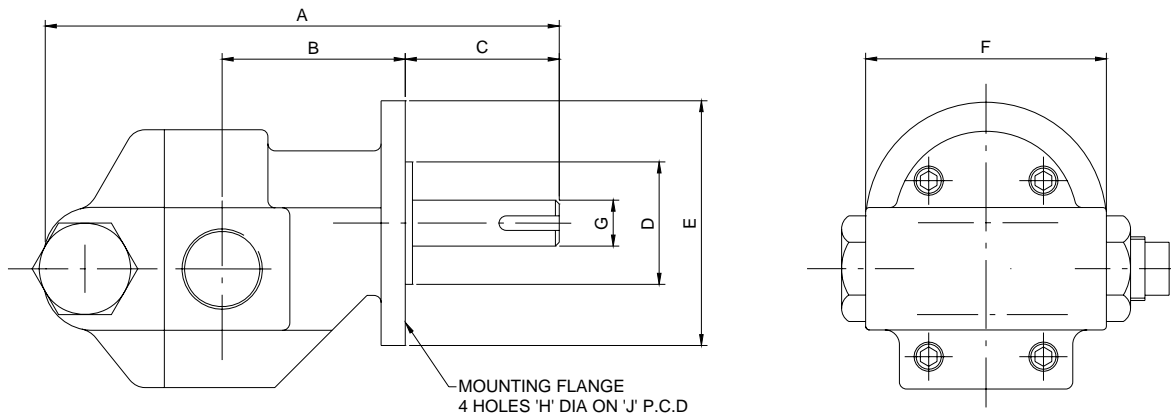

MODEL 'F'	mm								MOUNTING FLANGE		BRANCH BSP female	WEIGHT kg
	A	B	C	D	E	F	G	H	J			
40-1300	214	63	76	51	102	100	19	7	76	1"	6	
40-1750	225	62	76	51	102	100	19	7	76	1"	6.8	
40-2750	251	62	80	51	102	100	19	7	76	1.1/4"	8.5	

**MODEL TYPE 'O' 40 motorised available with: MECHANICAL SEAL**

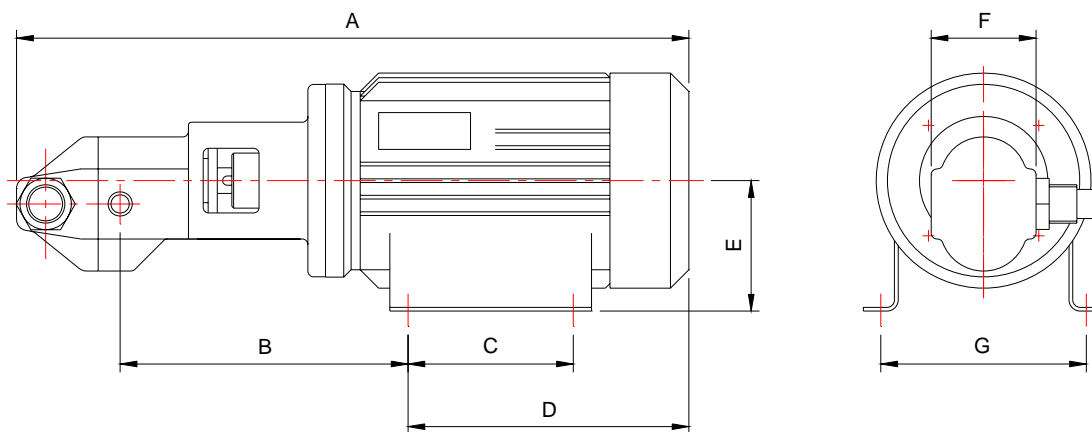

**Note: D100 & D112 motors will have an adaptor flange.**

MODEL 'O'	MOTOR		mm								BRANCH BSP female	WEIGHT kg	
			A	B	C		D	E	F	G			
40-1300	D90SC	D90LC	514	223	100	125	216	90	100	140	1"	21.7	23.7
40-1750	D90SC	D90LC	525	223	100	125	216	90	100	140	1"	22.5	24.5
40-2750	D90SC	D90LC	551	227	100	125	216	90	100	140	1.1/4"	24.2	26.2
40-1300	D100C		555	230	140		245	100	100	160	1"	33	
40-1750	D100C		566	230	140		245	100	100	160	1"	33.8	
40-2750	D100C		592	234	140		245	100	100	160	1.1/4"	35.5	
40-1300	D112C		561	237	140		248	112	100	190	1"	41	
40-1750	D112C		572	237	140		248	112	100	190	1"	41.8	
40-2750	D112C		598	241	140		248	112	100	190	1.1/4"	43.5	

## Performance

960 rev/min									1420 rev/min								
Model	Viscosity in cst	Capacity in litres/min at these pressures(bar g)				kW at these pressures(bar g)			Model	Viscosity in cst	Capacity in litres/min at these pressures(bar g)				kW at these pressures(bar g)		
		0	3.5	7	10	3.5	7	10			0	3.5	7	10	3.5	7	10
40-1300	35	31	28	25	22	0.55	0.75	1.1	40-1300	4	46	43	40	-	1.1	1.5	-
	125	31	30	29	28	0.75	1.1	1.5		125	46	45	44	43	1.1	1.5	2.2
	1250	31	30.5	30	29.5	1.1	1.5	2.2		750	46	45.5	45	44.5	2.2	3.0	3.0
40-1750	35	41	37	33	29	0.75	1.1	1.1	40-1750	4	61	57	53	-	1.1	2.2	-
	125	41	40	39	38	0.75	1.5	1.5		125	61	60	59	58	1.5	2.2	3.0
	1250	41	40.5	40	39.5	1.5	2.2	2.2		750	61	60.5	60	59.5	2.2	3.0	3.0
40-2750	35	66	61	56	51	1.1	1.5	1.5	40-2750	4	96	90	-	-	1.5	-	-
	125	66	65	63	62	1.1	2.2	2.2		125	96	95	94	93	1.5	3.0	4.0
	1250	66	65.5	-	-	2.2	-	-		750	96	95.5	95	-	3.0	4.0	-

Pumps for liquids with viscosities less than 4 centistokes and over 750 centistokes must be referred to Albany sales for selection.